

LN80600T104IA4598

10.4 inch, 800*600 pixels resolution, RGB interface, TN-TFT-LCD

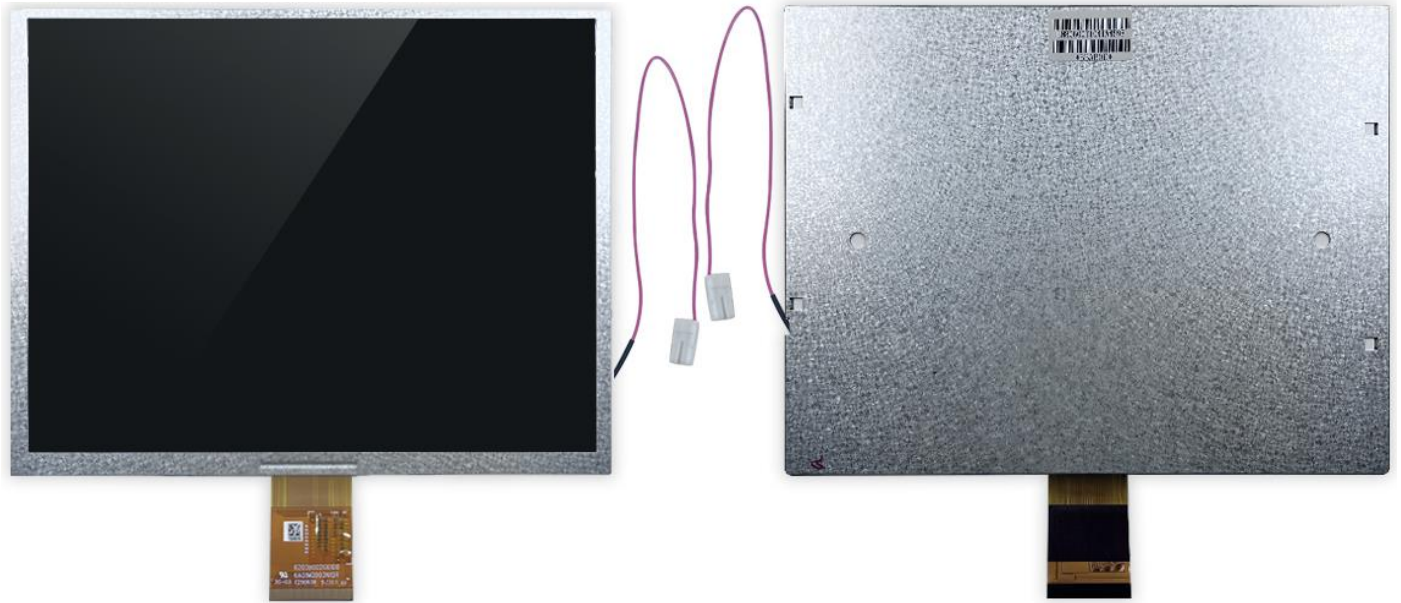

Disclaimer: The product design is subject to alternation and improvement without prior notice.

Table of Contents

1 General Feature.....	3
2 Mechanical Drawing.....	4
3 Input/Output Terminals.....	5
4 Electrical Characteristics.....	7
5 Timing Characteristics.....	8
6 Optical Characteristics.....	11
7 Environmental Reliability Test.....	14
8 Packing Capacity & Dimension.....	15
9 Appearance Inspection.....	16
10 Precautions for Use of LCD Modules.....	19
11 LCD Introduction.....	20

1 General Feature

Feature		Description	Unit
Display Spec.	Size	10.4	inch
	Resolution	800(H)*600(V)	pixels
	Pixel Configuration	RGB stripe	-
	Pixel Pitch	0.264(H)*0.264(V)	mm
	Viewing Direction	6 o'clock	-
Mechanical Characteristics	Outside Dimension	228.5(W)*175.5(H)*5.9(D)	mm
	Active Area	211.2(W)*158.4(H)	mm
	Luminance	450	cd/m ²
	LED Numbers	36 LEDS	-
	Pin Order	From left to right 60PIN	-
	Weight	390	g
Electrical Characteristics	Interface	RGB	-
	Color Depth	16.7M	colors
	Driver Condition	3.3(Type)	V
	Driver IC	HX8677/HX8264	-
Temperature Range	Operating Temp.	-20~70	°C
	Storage Temp.	-30~80	°C

Note: Requirements on Environmental Protection: RoHS.

2 Mechanical Drawing

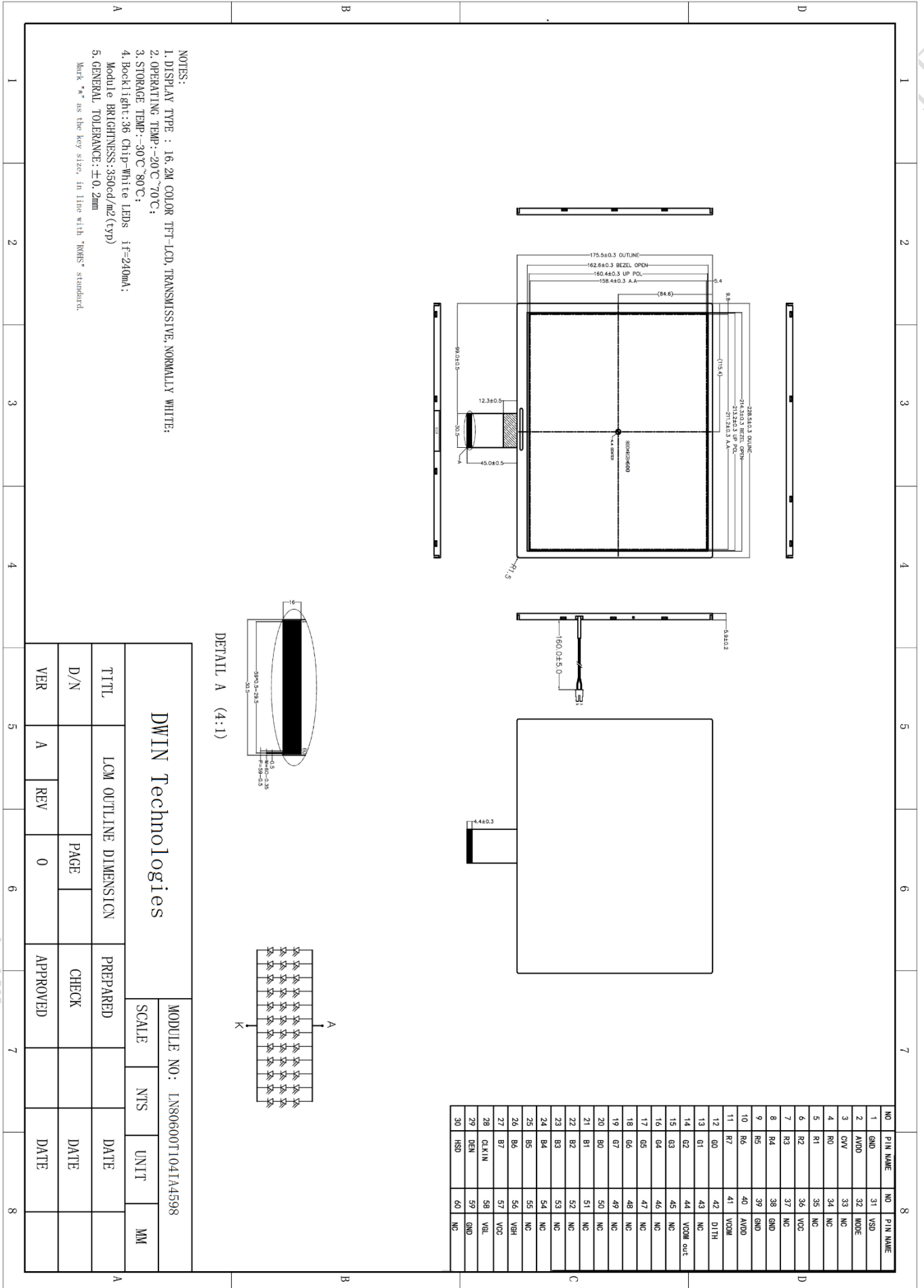

DWIN Technologies

MODULE NO: LN80600T1041A4598

TTTL		LCM OUTLINE DIMENSION		PREPARED	DATE
D/N		PAGE		CHECK	DATE
VER	A	REV	0	APPROVED	DATE
SCALE		NTS	UNIT	MM	

3 Input/Output Terminals

Pin NO.	Symbol	Function	Remark
1	GND	Power Ground	
2	AVDD	Analog input voltage	
3	VCC	Digital input voltage	
4	R0	Red data input (LSB)	
5	R1	Red data input	
6	R2	Red data input	
7	R3	Red data input	
8	R4	Red data input	
9	R5	Red data input	
10	R6	Red data input	
11	R7	Red data input (MSB)	
12	G0	Green data input (LSB)	
13	G1	Green data input	
14	G2	Green data input	
15	G3	Green data input	
16	G4	Green data input	
17	G5	Green data input	
18	G6	Green data input	
19	G7	Green data input (MSB)	
20	B0	Blue data input (LSB)	
21	B1	Blue data input	
22	B2	Blue data input	
23	B3	Blue data input	
24	B4	Blue data input	
25	B5	Blue data input	
26	B6	Blue data input	
27	B7	Blue data input (MSB)	
28	CLKIN	Dot clock input	
29	DEN	Data enable signal	
30	HSD	HSYNC signal	
31	VSD	VSYNC signal	
32	MODE	H: DE mode (Default) L: SYNC mode	
33	NC	No connect (please leave it open)	
34	NC	No connect (please leave it open)	
35	NC	No connect (please leave it open)	
36	VCC	Digital input voltage	
37	NC	No connect (please leave it open)	
38	GND	Power Ground	
39	GND	Power Ground	
40	AVDD	Analog input voltage	

41	VCOM	VCOM DC input	
42	DITH	Dithering function setting H: Disable dithering function L: Enable dithering function	
43	NC	No connect (please leave it open)	
44	VCOM out	Connect a capacitor	
45	NC	No connect (please leave it open)	
46	NC	No connect (please leave it open)	
47	NC	No connect (please leave it open)	
48	NC	No connect (please leave it open)	
49	NC	No connect (please leave it open)	
50	NC	No connect (please leave it open)	
51	NC	No connect (please leave it open)	
52	NC	No connect (please leave it open)	
53	NC	No connect (please leave it open)	
54	NC	No connect (please leave it open)	
55	NC	No connect (please leave it open)	
56	VGH	TFT turn on voltage	
57	VCC	Digital input voltage	
58	VGL	TFT turn off voltage	
59	GND	Power Ground	
60	NC	No connect (please leave it open)	

4 Electrical Characteristics

4.1 Driving TFT LCD Panel

Item	Symbol	Min.	Typ.	Max.	Unit	Remark
Digital Power Voltage	VCC	3.0	3.3	3.6	V	
Power for Analog Circuit	AVDD	11.5	12	12.5	V	
Gate on Voltage	VGH	-	18	-	V	
Gate off Voltage	VGL	-	-7	-	V	
Common Voltage	VCOM	-	5.3	-	V	

4.2 LED Backlight Specification

Item	Symbol	Min.	Typ.	Max.	Unit	Remark
Voltage for LED Backlight	VL	-	9.6	-	V	
Current for LED Backlight	IL	-	240	-	mA	
Luminance(with LCD)	Lv	-	450	-	cd/m ²	If=240mA
LED Life Time	--	-	30000	-	Hr	

Note: 36 LEDs (3 LEDs Serial, 12 ways Parallel)

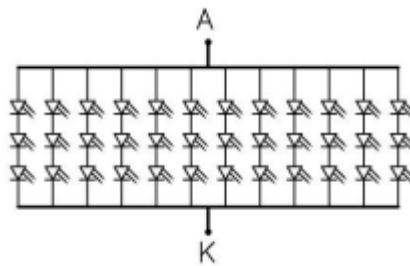

5 Timing Characteristics

5.1 Data Timing (Under Frame Rate is Equal to 60Hz)

5.1.1 Horizontal Timing

Item	Symbol	Min.	Typ.	Max.	Unit	Remark
Horizontal Display Area	thd	800			CLK	
CLK Frequency	fclk	-	40	50	MHz	
One Horizontal Line	th	862	1056	1200	CLK	
HS Pulse Width	thpw	1	-	40	CLK	
HS Front Porch	thfp	16	210	354	CLK	

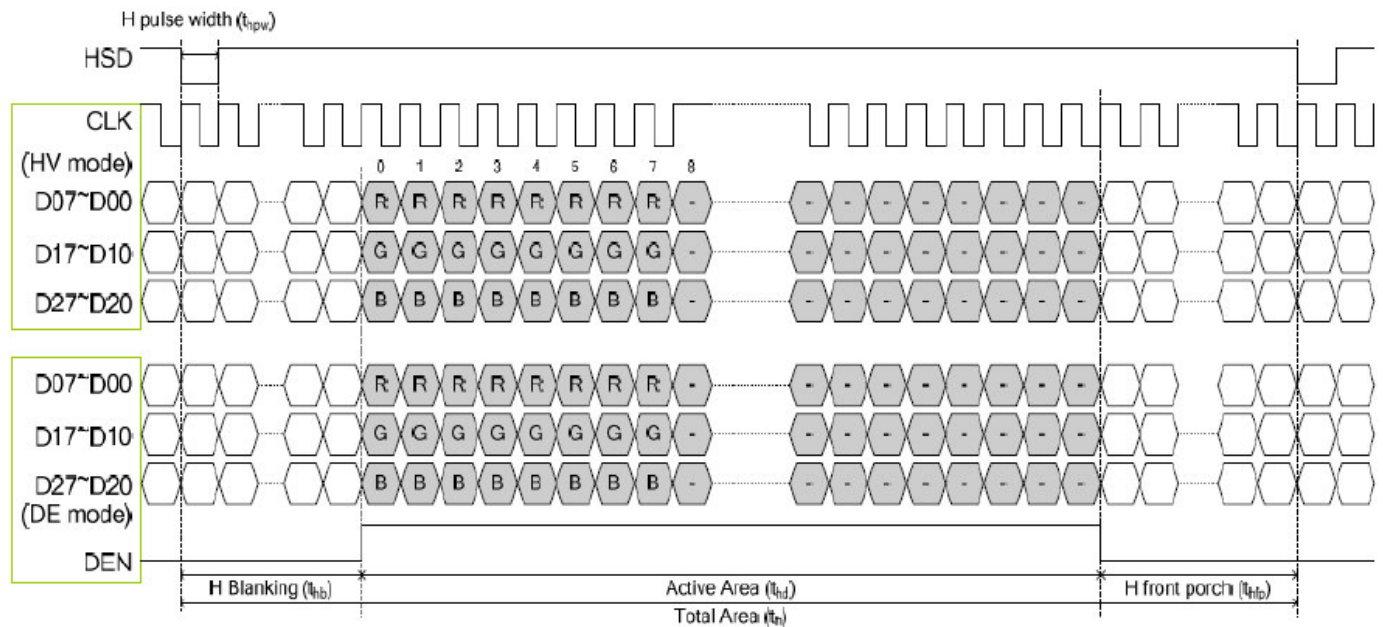

5.1.2 Vertical Timing

Item	Symbol	Min.	Typ.	Max.	Unit	Remark
Vertical Display Area	tvd	600			th	
VS Period Time	tv	624	635	700	th	
VS Pulse Width	tvpw	1	-	20	th	
VS Back Porch	tvb	23	23	23	th	
VS Front Porch	tvfp	1	12	77	th	

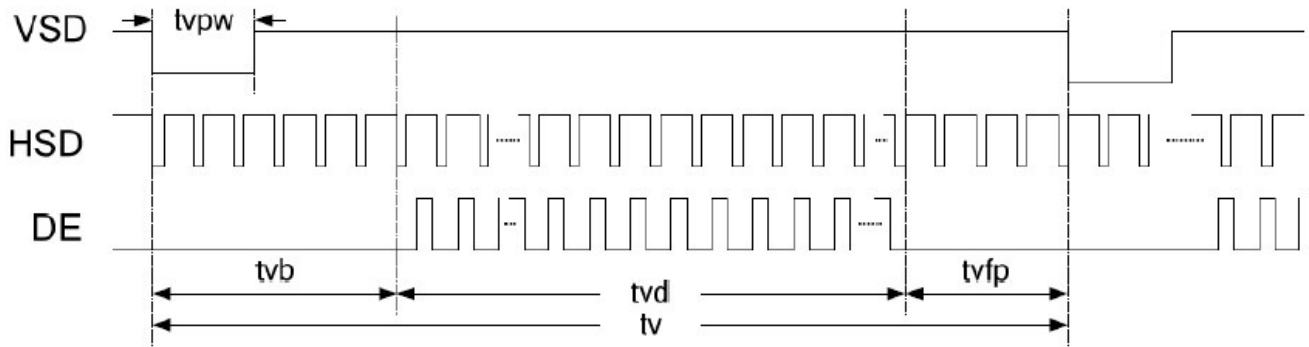

Note: CMO suggest using frame rate 60Hz to have better performance.

5.2 AC Electrical Characteristic

Item	Symbol	Min.	Typ.	Max.	Unit	Remark
HS Setup Time	Thst	8	-	-	ns	
HS Hold Time	Thhd	8	-	-	ns	
VS Setup Time	Tvst	8	-	-	ns	
VS Hold Time	Tvhd	8	-	-	ns	
Data Setup Time	Tdsu	8	-	-	ns	
Data Hold Time	Tdhd	8	-	-	ns	
DE Setup Time	Tesu	8	-	-	ns	
DE Hold Time	Tehd	8	-	-	ns	
VDD Power On Slew Rate	TPOR	-	-	20	ns	
RSTB Pulse Width	TRst	10	-	-	ns	
CLKIN Cycle Time	Tcph	20	-	-	ns	
CLKIN Pulse Duty	Tcwh	40	50	60	%	
Output Stable Time	Tsst	-	-	6	ns	
Repair OPA Output Stable Time	TRsst	-	-	6	ns	

5.3 Input Clock and Data Timing Waveform

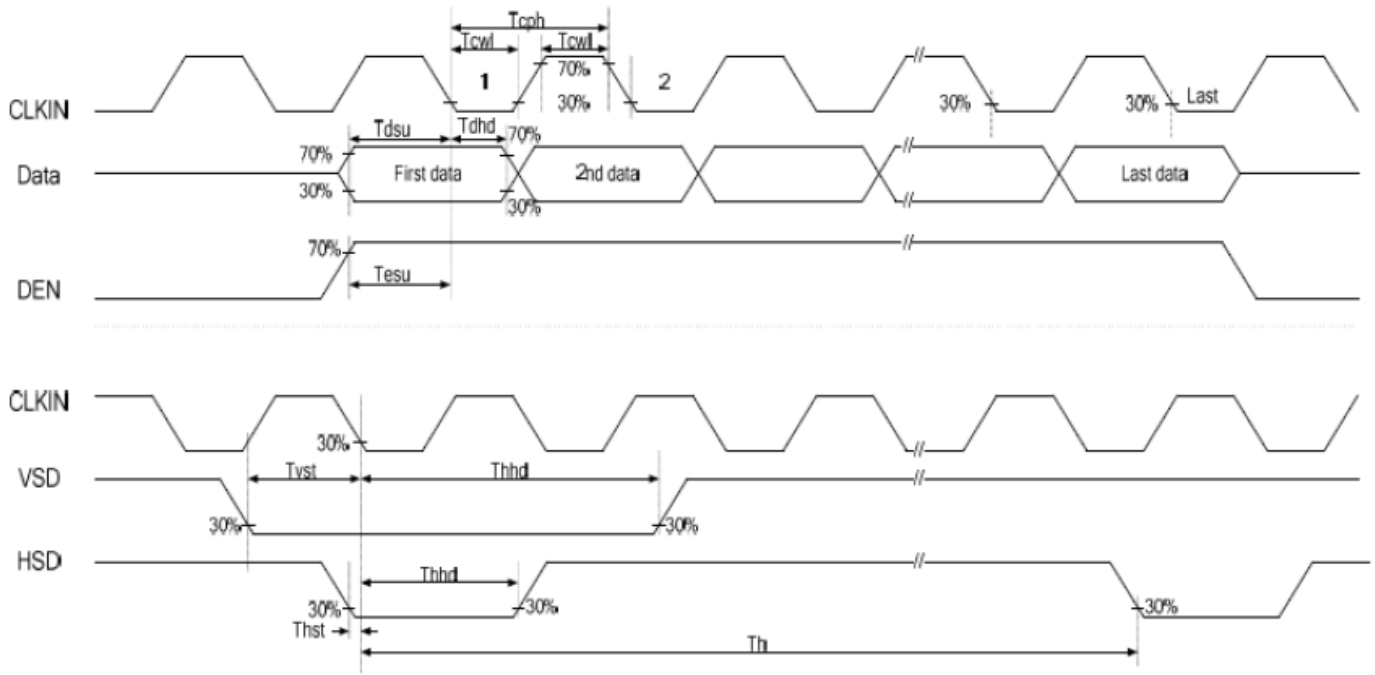

6 Optical Characteristics

Item	Symbol	Condition	Min.	Typ.	Max.	Unit	Remark
Viewing Angle	Top	$CR \geq 10$	40	50	-	Deg.	Note 2
	Bottom		50	60	-		
	Left		60	70	-		
	Right		60	70	-		
Contrast Ratio	CR	$\theta=0^\circ$	300	500	-		
Response Time	T_{ON}	25°C	-	10	15	ms	Note 4
	T_{OFF}		-	15	25	ms	Note 4
Color Chromaticity (CIE1931)	W_x		0.225	0.275	0.325		Note 1
	W_y		0.293	0.343	0.393		
	R_x		0.223	0.273	0.323		
	R_y		0.411	0.461	0.511		
	G_x		0.503	0.553	0.603		
	G_y		0.310	0.360	0.410		
	B_x		0.102	0.152	0.202		
	B_y		0.086	0.136	0.185		

Test conditions:

IF= 240 mA, and the ambient temperature is 25°C.

Note 1: Definition of optical measurement system.

The optical characteristics should be measured in dark room. After 5 minutes operation, the optical properties are measured at the center point of LCD.

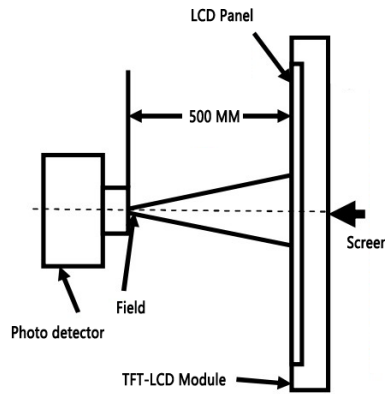

Note 2: Definition of viewing angle range and measurement system.

The viewing angle is measured at the center point of the LCD by BM-7A.

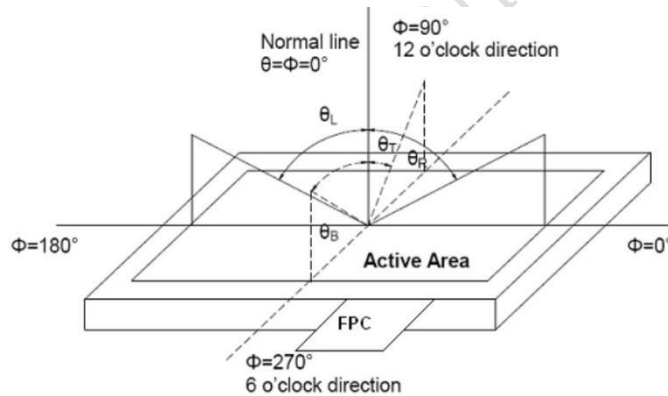

Note 3: Definition of color temperature.

When the radiation of the light source is exactly the same in the visible region and the absolute blackbody, the temperature of the blackbody is called the color temperature of the light source. Color temperature is an index to measure the degree of light source color (cold color, warm color). Warm color < 3300K, intermediate color 3300 ~ 5000K, cold color > 5000K.

Note 4: Definition of response time.

The response time is defined as the LCD optical switching time interval between “White” state and “Black” state. Time ON (TON) is the time between photo detector output intensity changed from 90% to 10%. And time off (TOFF) is the time between photo detector output intensity changed from 10% to 90%.

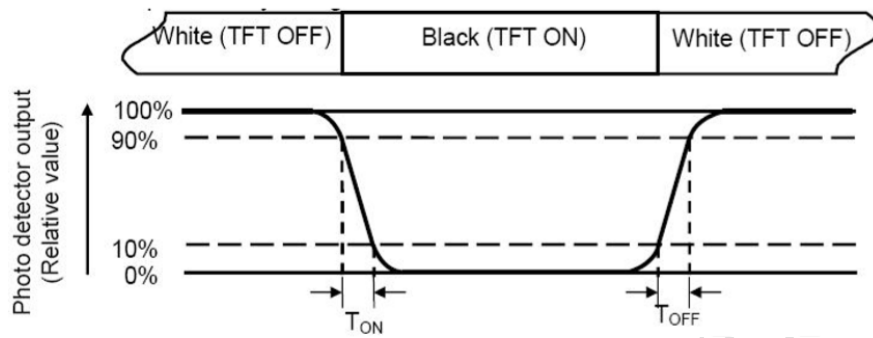

7 Environmental Reliability Test

NO	Test Item	Condition	Remarks
1	High Temperature Operation	Ta=+70°C, 240hours	IEC60068-2-1:2007 GB2423.2-2008
2	Low Temperature Operation	Ta=-20°C, 240hours	IEC60068-2-1:2007 GB2423.1-2008
3	High Temperature Storage	Ta=+80°C, 240hours	IEC60068-2-1:2007 GB2423.2-2008
4	Low Temperature Storage	Ta=-30°C, 240hours	IEC60068-2-1:2007 GB2423.1-2008
5	Storage at High Temperature and Humidity	Ta=+60°C, 90% RH max, 240hours	IEC60068-2-78 :2001 GB/T2423.3-2006
6	Thermal Shock (non-operation)	-20°C 30 min~+70°C 30 min, Change time: 5min, 10 Cycle	Start with cold temperature, End with high temperature, IEC60068-2-14:1984, GB 2423.22-2002
7	ESD(non-operation)	C=150pF, R=330Ω,5point/panel Air: ±15Kv,5times; Contact: ±6Kv,5times (Environment:15°C~35°C, 30%~60%.86Kpa~106Kpa)	IEC61000-4-2:2001 GB/T 17626.2-2006
8	Vibration Test	Frequency range:10~55Hz Stroke:1.5mm Sweep:10Hz~55Hz~10Hz 2 hours for each direction of X.Y.Z. (6 hours for total)	IEC60068-2-6:1982 GB/T 2423.10-1995
9	Mechanical Shock (non-operation)	Half Sine Wave 60G 6ms, ±X, ±Y, ±Z 3times for each direction	IEC60068-2-27:1987 GB/T 2423.5-1995
10	Package Drop Test	Height:80cm,1corner,3 edges,6 surfaces	IEC60068-2-32:1990 GB/T 2423.8-1995

8 Packing Capacity & Dimension

Dimension			
Dimension(mm)	228.5(W)*175.5(H)*5.9(D)		
Net Weight	390g		
Packing Capacity			
Size	LCD Size and Resolution	Layer	Quantity(Pcs)
320mm(L)x270mm(W)x80mm(H)	10.4 inch 800*600	1	1
600mm(L)x430mm(W)x290mm(H)	10.4 inch 800*600	1	20

Packing instruction:

The LCD is placed in the grid, covered with a PE static bag and compactly assembled, the upper and the lower layers of the grid are protected by buffer spaces.

The LCD covered with a PE static bag and compactly assembled



placed in the grid



The upper and the lower layers of the grid are protected by buffer spaces



Packed



9 Appearance Inspection

9.1 General rules for inspection

9.1.1 Anti-static wearables (anti-static wristbands, gloves) must be worn during the inspection.

9.1.2 Do not use bare hands to touch the position of the device, golden fingers, and the surface of the screen to prevent the sweat from human hands from causing oxidation and affecting the appearance.

9.1.3 It is forbidden to stack products out of specification and handle them with care to avoid damage to components.

9.1.4 The repaired products need to be inspected to prevent rosin and tin slag from exceeding the specifications.

9.1.5 When technical documents and process documents have specific requirements for products, the technical documents and process documents shall be the main requirements.

9.2 Inspection conditions

9.2.1 The conditions of display function check

Angle: $\pm 5^\circ$;

Inspection method: visual inspection. The inspection object is 30-40cm away from the light source, and the eye is 30-40cm away from the inspection object;

Illumination: 300-500Lux;

Inspection time: 5-10S.

9.2.2 Visual inspection conditions

Angle: $\pm 45^\circ$;

Inspection method: visual inspection. The inspection object is 30-40cm away from the light source, and the eye is 30-40cm away from the inspection object;

Illumination: 800-1500Lux;

Inspection time: 5-10S.

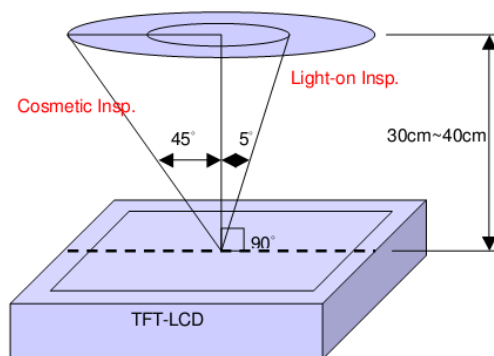

9.3 Inspection standards

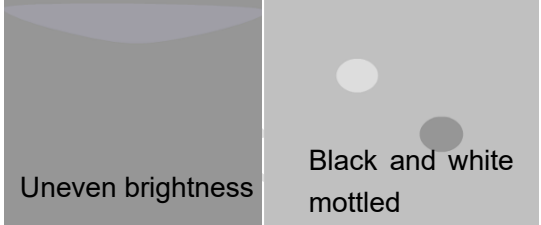
Type	Test Items	Judgement Standard	Defect Category
Display state	Dead pixels	No dead pixels	
	mura	<p>From different angles, the brightness is required to be uniform. Under the 64-level grayscale or pure black interface, there should be no uneven display brightness within the viewing angle range of 45° through 6% ND FILTER. Y series (TV film) LCD screen does not have specific requirements, and the picture inspection does not affect the display as qualified.</p> 	Slight defect
	Light leakage	<p>Under the 64-level grayscale or pure black interface, there should be no obvious light leakage within the viewing angle range of 45° by visual inspection or through 6% ND FILTER. Y series (TV LCD screen) series can be without obvious visual defects.</p>	Slight defect
	Linear foreign bodies	<p>1. $W \leq 0.05$, $L \leq 2\text{mm}$, negligible; 2. $0.05\text{mm} < W \leq 0.1\text{mm}$, $L \leq 2\text{mm}$, $N \leq 3$; 3. $W > 0.1\text{mm}$, $L > 2\text{mm}$, not allowed.</p>	Slight defect
Screen surface	Within the effective area	<p>Spotted: 1. $D \leq 0.2\text{mm}$ and it is not a piece, it is not counted; 2. $0.2\text{mm} < D \leq 0.5\text{mm}$, $N \leq 3$; 3. $D > 0.5\text{mm}$, $L > 0.5\text{mm}$, $W > 0.5\text{mm}$ are not allowed; (The spotted foreign objects shall not exceed the point-line gauge $D=0.5$, and the black dot coverage shall be checked, and the spotted foreign objects shall be judged within the range of $D=0.5$)</p>	Slight defect

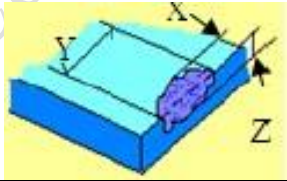
	Foreign objects Scratch Air bubbles	Linear: 1. $W \leq 0.05$, $L \leq 2\text{mm}$, ignored; 2. $0.05 < W \leq 0.1\text{mm}$, $L \leq 2\text{mm}$, $N \leq 3$; 3. $W > 0.1\text{mm}$, $L > 2\text{mm}$, not allowed.	
	Outside the effective area Foreign objects Scratches Air bubbles	Foreign objects are not checked, and bubbles are not allowed to $D > 1\text{mm}$; Non-inductive scratches of no more than $0.1 \times 8\text{mm}$ are allowed.	Slight defect
	Crack	Not allowed.	 Slight defect
	Notch	1. Does not affect the appearance from the front; 2. Does not affect the relevant alignment; 3. $X \leq 1\text{mm}$, $Y \leq 1\text{mm}$, $N \leq 2$.	 Slight defect
	Glass side Foreign objects Dirty	1. The foreign body on the side is not controlled; 2. The paint pen marks on the side are not controlled; 3. Side oily note printing is not allowed.	Slight defect
FPC	Cracks Goldfinger crease	Not allowed.	Heavy deficit
	Crease	Slight creases are not controlled; The crease is whitish and has lines, which is not allowed.	Heavy deficit
	Top wound, stab wound	No damage to the line, $D \leq 0.2\text{mm}$; Damage to the line is not allowed.	Heavy deficit
	Scratch	Slight scratches on the surface are not controlled; Damage to the line is not allowed.	Heavy deficit
	Goldfinger scratch	$W \leq 0.05\text{mm}$, no control; $W > 0.05\text{mm}$, not allowed; Test probe tip marks are not controlled.	Heavy deficit
	Component	Under-soldering, over-soldering and false soldering are not allowed.	Heavy deficit

10 Precautions for Use of LCD Modules

10.1 Handling Precautions

10.1.1 The display panel is made of glass. Do not subject it to a mechanical shock by dropping it from a high place, etc.

10.1.2 If the display panel is damaged and the liquid crystal substance inside it leaks out, be sure not to get any in your mouth, if the substance comes into contact with your skin or clothes, promptly wash it off using soap and water.

10.1.3 Do not apply excessive force to the display surface or the adjoining areas since this may cause the color tone to vary.

10.1.4 The polarizer covering the display surface of the LCD module is soft and easily scratched. Handle this polarizer carefully.

10.1.5 If the display surface is contaminated, breathe on the surface and gently wipe it with a soft dry cloth. If still not completely clear, Can only use LCD dedicated cleaner, the following organic solvent can not be used:

- Isopropyl alcohol
- Ethyl alcohol
- Ketone
- Aromatic solvents

10.1.6 Do not attempt to disassemble the LCD Module.

10.1.7 If the logic circuit power is off, do not apply the input signals.

10.1.8 To prevent destruction of the elements by static electricity, be careful to maintain an

10.1.9 optimum work environment.

10.1.9.1 Be sure to ground the body when handling the LCD Modules.

10.1.9.2 Tools required for assembly, such as soldering irons, must be properly ground.

10.1.9.3 To reduce the amount of static electricity generated, do not conduct assembly and other work under dry conditions.

10.1.9.4 The LCD Module is coated with a film to protect the display surface. Be care when peeling off this protective film since static electricity may be generated.

10.2 Storage precautions

10.2.1 When storing the LCD modules, avoid exposure to direct sunlight or to the light of fluorescent lamps.

10.2.2 The LCD modules should be stored under the storage temperature range. If the LCD modules will be stored for a long time, the recommend condition is:

Temperature: 0°C ~ 40°C Relatively humidity: ≤80%.

10.2.3 The LCD modules should be stored in the room without acid, alkali and harmful gas.

10.3 Transportation Precautions

10.3.1 The LCD modules should be no falling and violent shocking during transportation, and also should avoid excessive press, water, damp and sunshine.

11 LCD Introduction

11.1 Process capacity

DWIN adopts original class A glass and the entire production is in the park from cleaning, cutting, bonding, and laminating of large glass to backlight assembly, quality inspection, and aging.

There are 12,000 square meters of clean workshop, with a monthly production capacity of about 2.5 million pieces. Each piece of LCD produced in the factory is for 30 days of aging.



11.2 ODM service

Based on LCD products of 1.5~21.5 inches, DWIN provides the following customization services.

1、LCD HDMI interface customization.

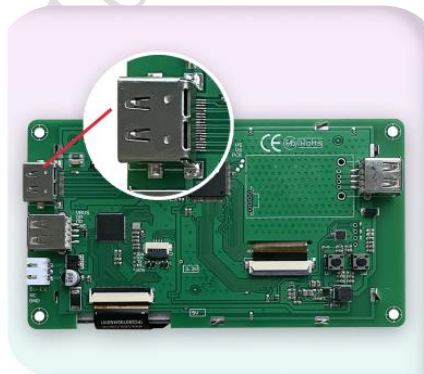

HDMI interface

2、Special screen customization such as high luminance, ultra-wide temperature and strong electromagnetic protection.

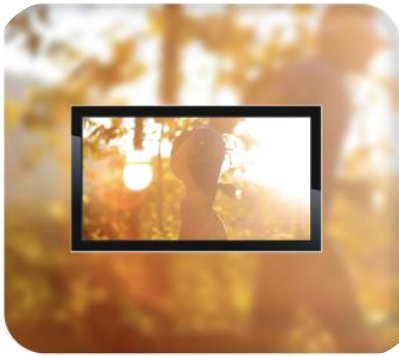

High luminance
(up to 1200nit)



Ultra-wide temperature
(-40~85℃)



Strong electromagnetic
protection

3、Lamination customization service of LCD + TP.



LCM+RTP



LCM+CTP

4、Customization service of DWIN self-developed T5L ASIC+ LCD + TP.



5、Smart screen finished product customization.

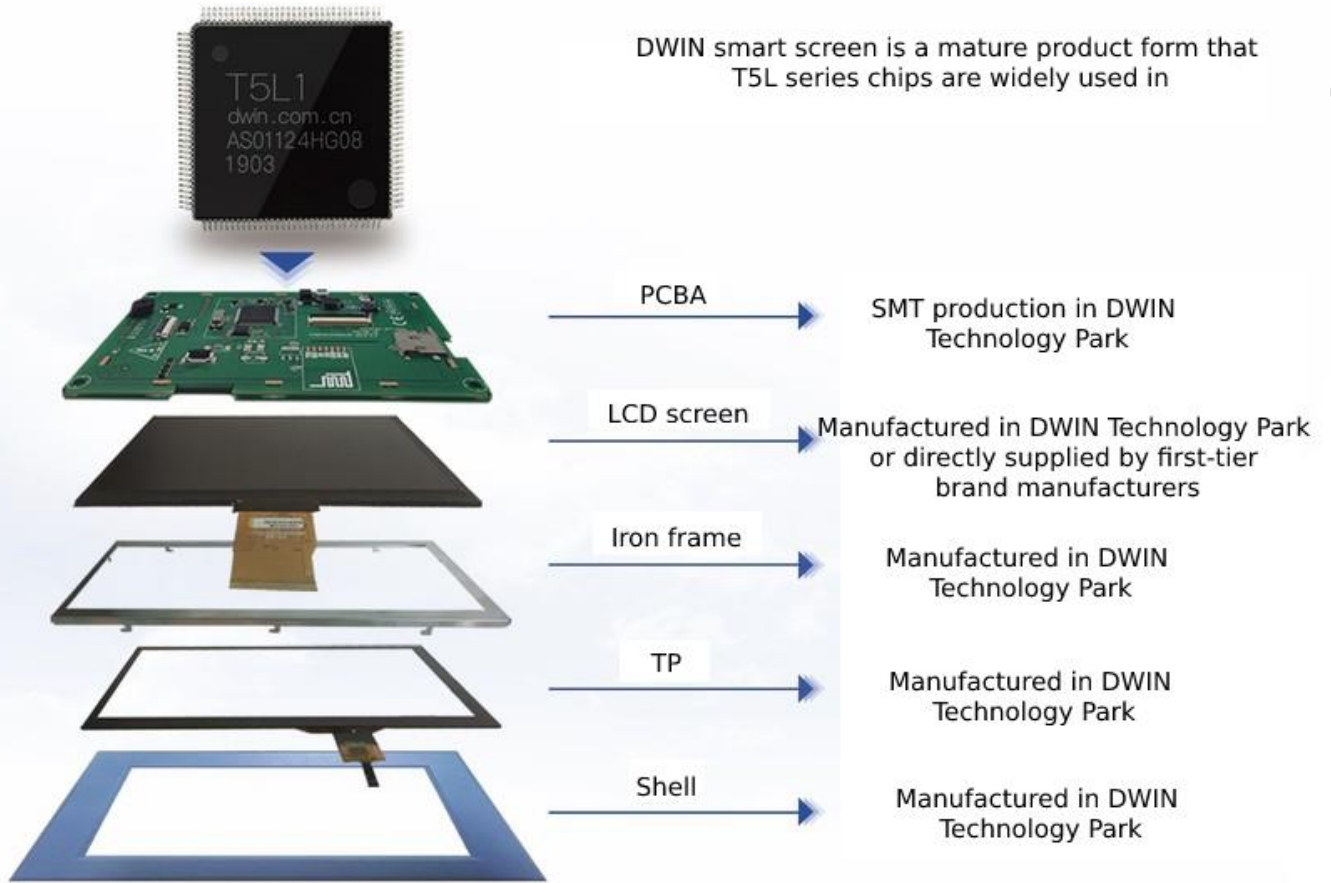

Please contact our sales staff for other customization needs.

Record of Revision

Rev	Date	Description	Editor
00	2019-11-11	First Release	Xue Qiong
01	2020-11-12	Update the Corresponding Time	Zhou Biao
02	2023-01-04	Update the Outsize Dimension, add Product Picture and Add Driver IC	Chen Xian

Please contact us if you have any questions about the use of this document or our products, or if you would like to know the latest information about our products:

Customer service tel: +86 400 018 9008

Customer service email: dwinhmi@dwin.com.cn

DWIN developer forum: <https://forums.dwin-global.com/index.php/forums/>

Thank you all for continuous support of DWIN, and your approval is the driving force of our progress!